



Maintenance Control Program (MCP)

WARNING:

Failure to conduct proper maintenance or negligence in maintenance procedures can lead to accidents and fatal injuries. Omitted or poorly executed maintenance may result in malfunctioning of the hydraulic system, posing a significant risk to personnel. Additionally, improper troubleshooting procedures can further exacerbate the danger.

It is imperative to thoroughly read and adhere to all instructions provided in this section. In addition to the safety guidelines outlined in Section 2 "For Your Safety," please take heed of the following precautions:

WARNING:

Working on the hydraulic power pack carries inherent risks of injury from electrical, mechanical, or hydraulic hazards, which could lead to serious harm or death. Before commencing any work on the hydraulic power pack, ensure to disconnect the power supply from the drive motor. Likewise, before initiating any maintenance on the hydraulic power pack, relieve the pressure in the hydraulic system to prevent potential accidents.

CAUTION:

During operation, the hydraulic power pack and valves' solenoids may attain elevated temperatures, posing a risk of minor burns. If surface temperatures exceed 60°C, exercise caution and allow adequate time for the hydraulic power pack and solenoids to cool down before handling them.



Overview

The HydraSafe Brake is meticulously engineered to surpass the safety standards outlined in the Unintended/Ascending Elevator Code A17.1 2.19, ensuring optimal safety as a critical component in any traction elevator system. Moreover, its versatile design allows for seamless adaptation to meet the requirements of A17.1 3.17 for hydraulic elevators utilizing a "T" rail configuration.

Examinations and testing procedures for the HydraSafe Brake adhere strictly to, but are not restricted to, ASME A17.1 8.6.4.19.11 specifications concerning Ascending Car Overspeed Protection, Unintended Car Movement Devices, and Emergency Brake protocols. Maintenance procedures are standardized across both traction and hydraulic elevator systems to guarantee uniform safety standards.

While HydraSafe Brake recommends monthly maintenance checks for optimal performance, such frequency is not mandatory and should instead be determined based on contractual agreements or guidelines set forth by the Authority Having Jurisdiction (AHJ), in conjunction with ASME code compliance regulations. We advise incorporating these maintenance procedures into your scheduled visits to ensure the continued reliability and safety of our product line.

1. Conduct a visual inspection of the unit on a monthly basis or during the next scheduled maintenance visit. Check for any signs of damage, such as cracks or dents, and inspect for oil leaks around seals. Ensure all components are securely fastened and there are proper clearances between the brake pad and guide rail. Wipe clean any oil residue to maintain optimal performance.
2. Annually, the HydraSafe Brake unit must undergo testing to verify proper operation in accordance with A17.1 8.6.4.19.11 standards for code compliance.
3. Every 5 years or 60 months, the HydraSafe Brake unit should undergo a comprehensive test per ASME A17.1 8.6.4.19.11 code. This test includes conducting assessments at full load capacity, as determined individually for each elevator being tested, and at 125% capacity to ensure adherence to Unintended/Ascending capabilities, as specified by the Authority Having Jurisdiction (AHJ) and ASME Code.

Brake Unit

The HydraSafe Brake comprises two main components: the Brake Unit and the Power Unit, which is enclosed within the Brake Unit.

Brake Unit Components:

- Safety switch (two per device)
- Brake pads (two per device)
- Retracting springs for each brake pad (four total per device)
- Stainless pistons (two per device)
- Wiper seal (two per device)
- Pressure seal (two per device)
- Back plate seal (two per device)
- Bleeder valve/fitting (two per device)
- SS-400-1-4 fittings male (two per device)
- SS-400-3 Fitting Union Tee (one per device)
- Brake pad wear sensors if applicable (two per device)



Brake Unit – Caliper to Rail Diagram

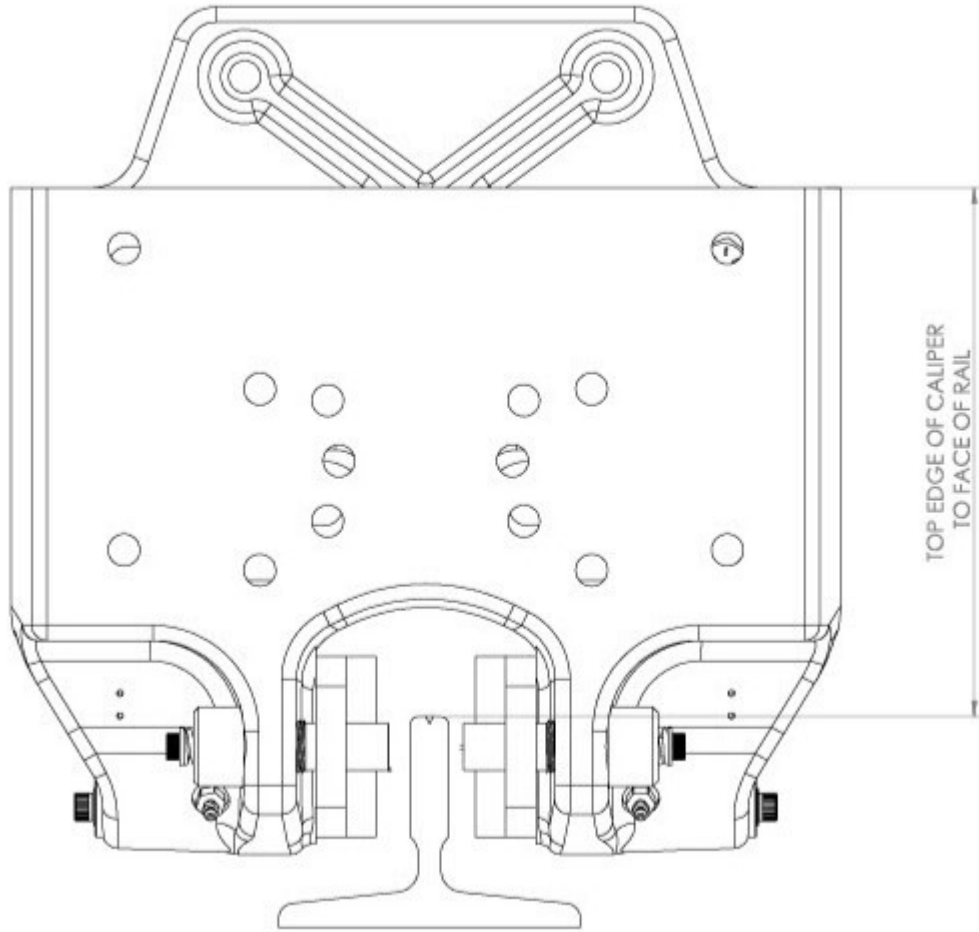

8LB RAIL: 9 - 3/8"

12LB RAIL: 8 - 15/16"

15LB RAIL: 8 - 3/4"

18LB RAIL: 8 - 3/4"

22LB RAIL: 8 - 3/4"

30LB RAIL: 8 - 1/2"

Brake Unit – Caliper Diagram

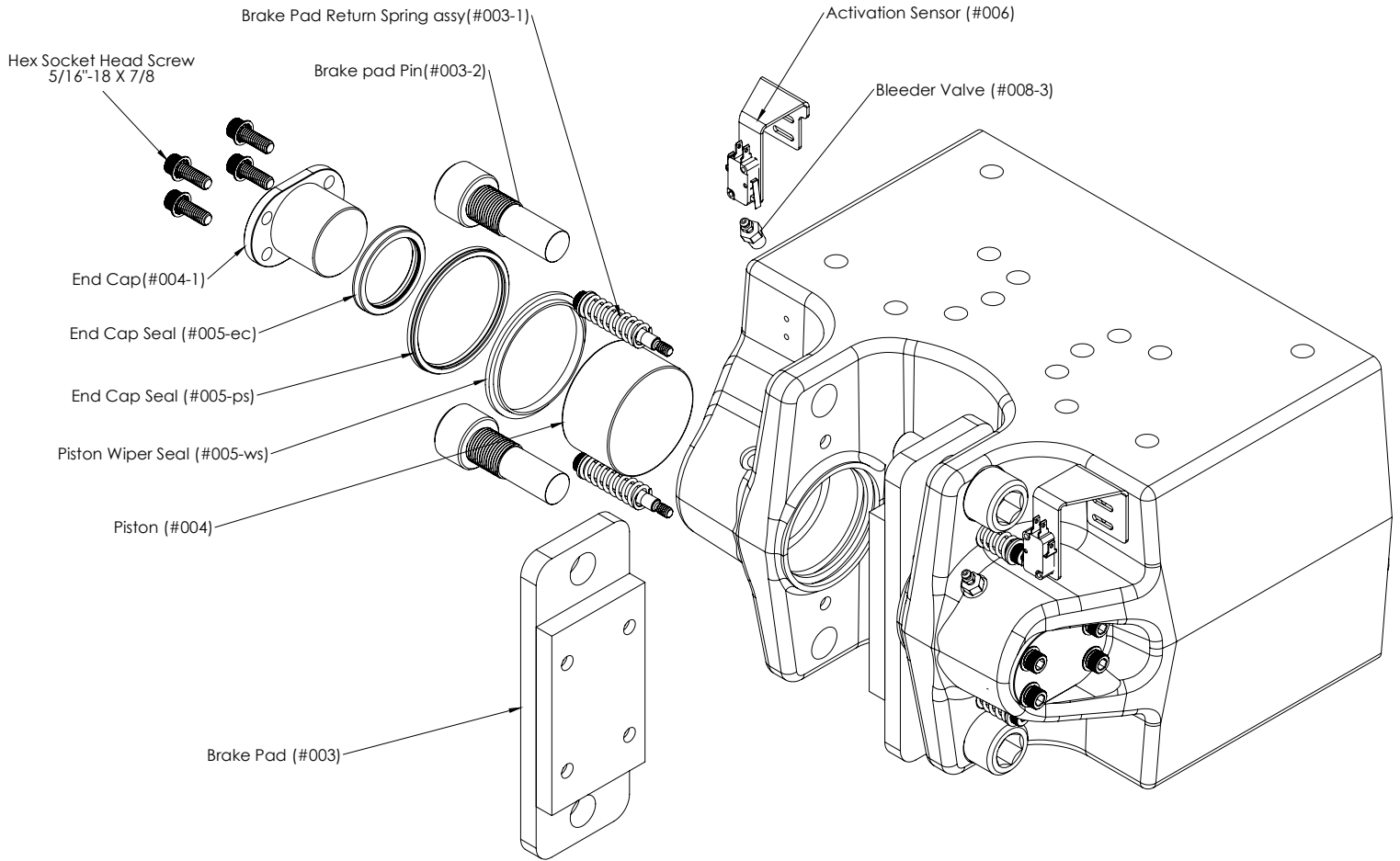

Submersible Power Unit

Power Unit Components:

- Submersible Power unit with internal motor 120- volts (One Per Device).
- On board diagnostics module.
- Built in oil reservoir with filler cap and level sensor.
- Two 120-volt relays with normally open and closed contacts.
- One fuse block and 20A Fuse.
- Encloser is UL approved electrical box which houses all components.
- Accumulator Valve type HPS
- Hydraulic 3/8" hose (5800 PSI) with quick connect from valve to caliper.

Power Unit Diagram

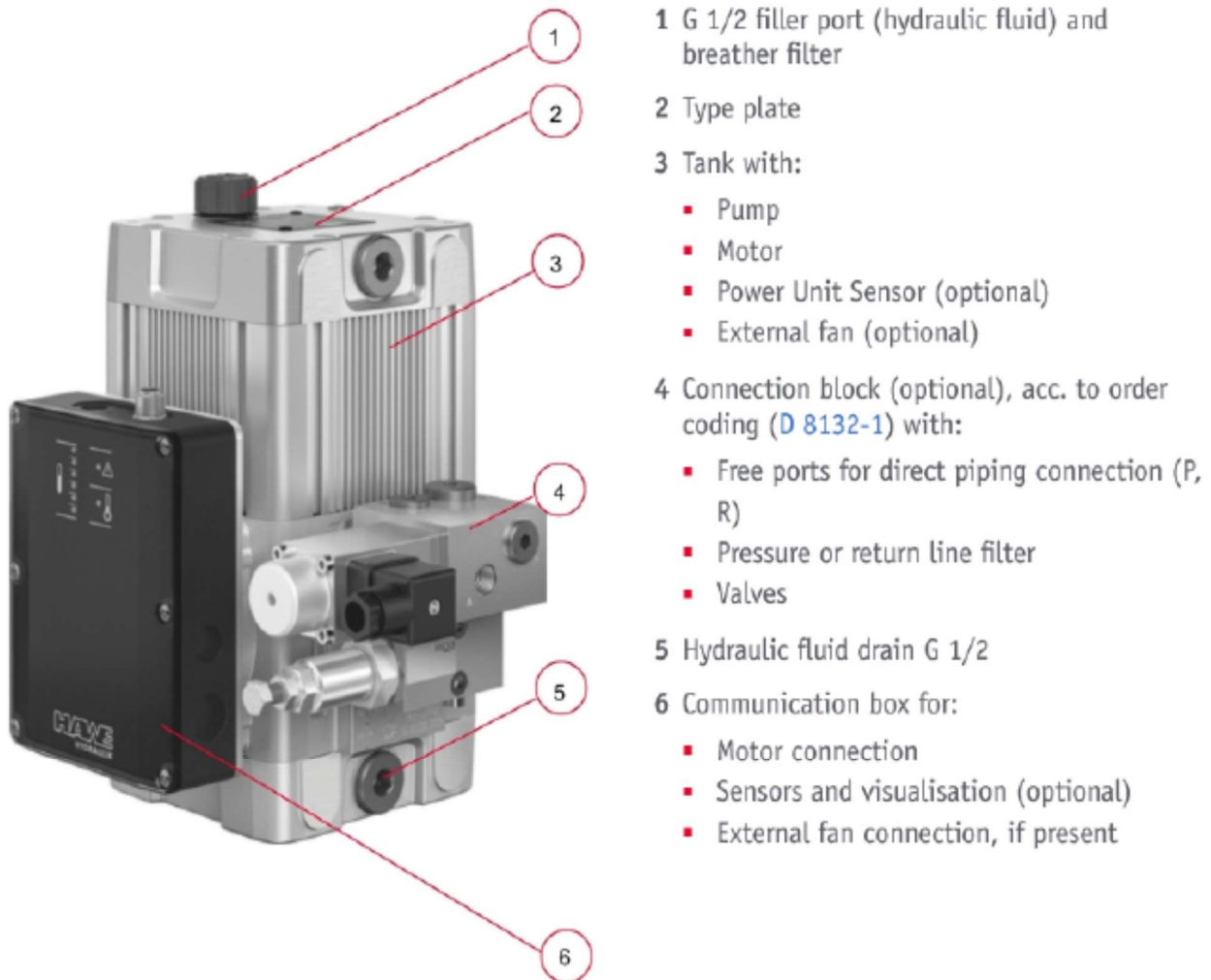

- 1 G 1/2 filler port (hydraulic fluid) and breather filter
- 2 Type plate
- 3 Tank with:
 - Pump
 - Motor
 - Power Unit Sensor (optional)
 - External fan (optional)
- 4 Connection block (optional), acc. to order coding (D 8132-1) with:
 - Free ports for direct piping connection (P, R)
 - Pressure or return line filter
 - Valves
- 5 Hydraulic fluid drain G 1/2
- 6 Communication box for:
 - Motor connection
 - Sensors and visualisation (optional)
 - External fan connection, if present

ITEM NUMBER	PART NUMBER	DESCRIPTION	QTY.
1	HB-SS-400-2-4PR	Positionable Male Elbow, ISO Parallel Thread	5
2	HB-SS-400-3	1/4" Union Tee	1
3	HB-SS-401-PC	1/4" Port Connector	1
4	HB-SS400-3-4TTF	Female Branch Tree	2
5	HB-SS-T4-S-065-20	316SS 1/4" 0.065" Wall Tubing	5 FT
6	HB-OS-PD343	QC Stem, 1/4" MNPT	1
7	HB-OS-PD242	QC Body, 1/4" FNPT	1
8	HB-SS-TA-1-4RS	Male Adapter (ISO Parallel Thread)	1
9	HB-SS-400-2-4	Male Elbow	1
10	HB-OS-PKR-HS	Parker Hose, 1/4" MNPT Ends, 12.5"	1
11	HB-OS-PD342	QC Stem, 1/4" FNPT	1
12	HB-SS-4-SE	Street Elbow	1
13	HB-SS-400-1-4	Male Connector	2
14	HB-SS-4-RS-2V	ISO Parallel Thread Gasket	1

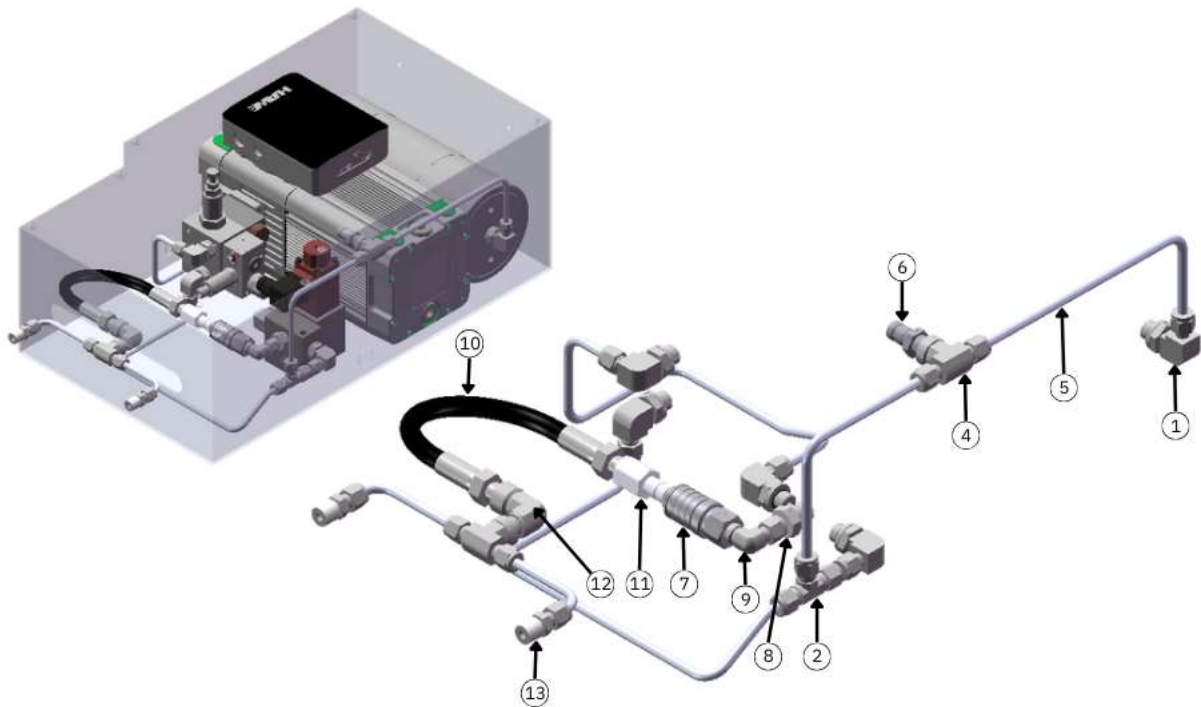

Power Unit – Accumulator

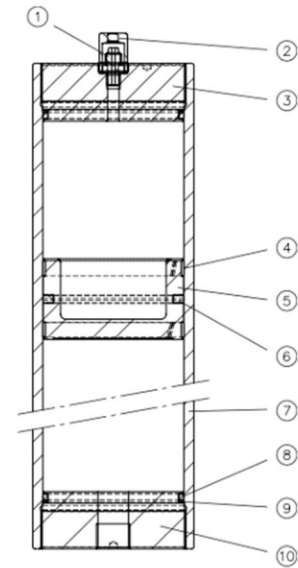

- 1. Gas valve
- 2. Valve Protection
- 3. Gas flange
- 4. Guide ring
- 5. Piston
- 6. Piston seal
- 7. Cylinder tube
- 8. Flange seal
- 9. Back up ring
- 10. Fluid flange

Power Unit – Electrical Diagram

Alternating current

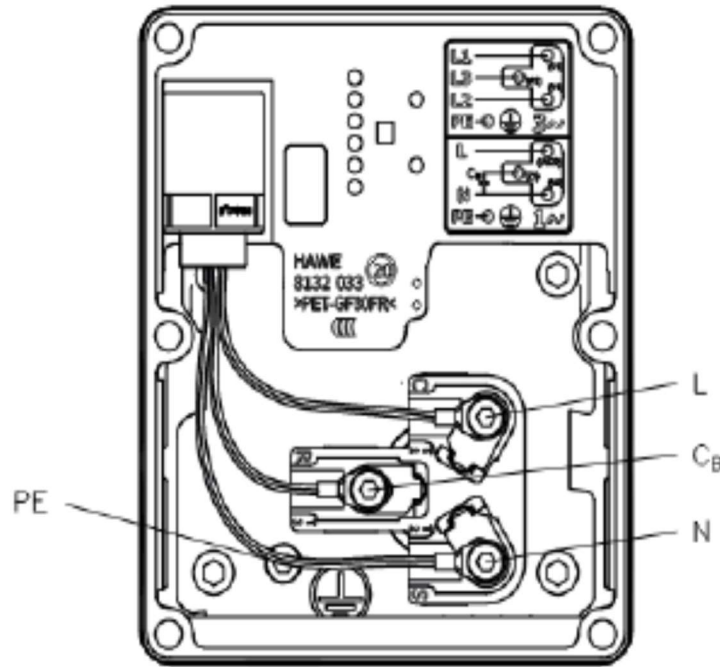

L	U1/Z2
N	U2
C _B	Z2
PE	⊕

Alternating current

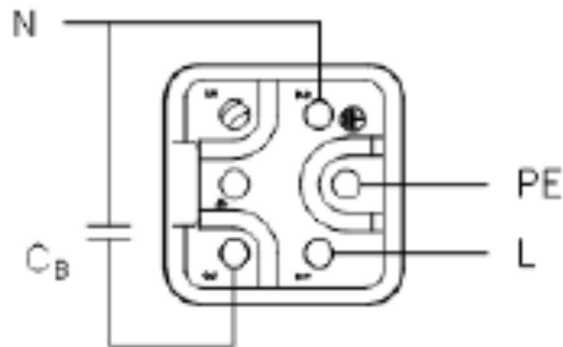

Power Unit – Electrical Diagram

System Logic:

1. Each power unit will run the motor to maintain accumulator pressure automatically, based on the pressure settings of the pressure switch
2. Valve Coil voltage is high, and drops on the demand from the controller (loss of EB Signal) when unintended or ascending car input goes high. Valve coil will also drop with loss of power per code.
3. Valve coil drops and releases the hydraulic flow to the calipers and sets the device. 4. When the EB signal is restored per code, the coil picks and opens the brakes. In event of a power loss, when power is restored the coil will pick and open the brakes. 5. Brake Picked input signals the controller that the brakes are reset and the elevator is ready to run.

- Wire list:
- #1- 110VAC from controller
 - #2- EB from controller
 - #3- +24 VDC from controller
 - #4- Common / Neutral
 - #5 - Brake Picked output (Voltage dependent on control requirement)
 - #6 - Brake pad wear sensor (optional)
 - #7 - Spare

RED 110 VAC

BLUE 24 VDC

GREEN Common / Neutral

110 VAC 10 AMP
From Elevator Controller

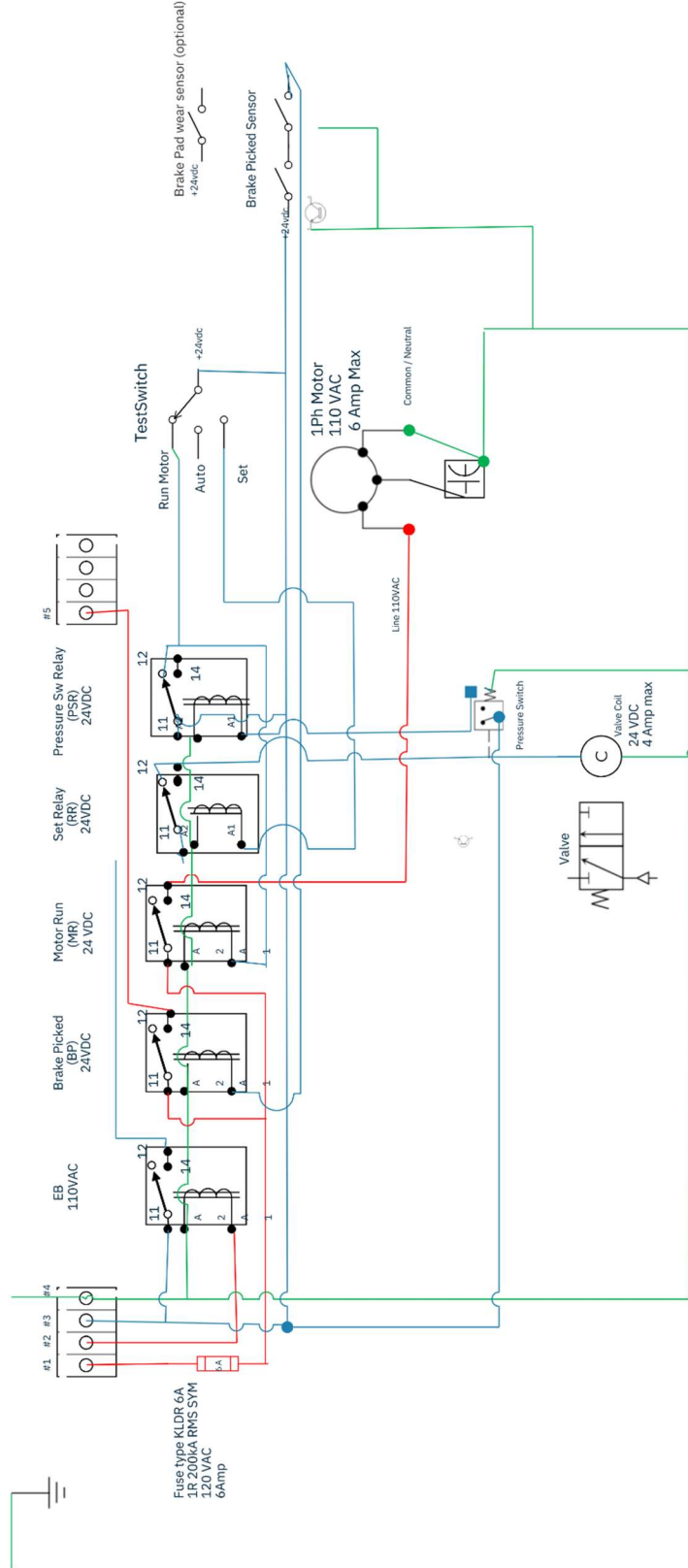

Brake Unit – Maintenance

- Maintenance tasks should only be undertaken by qualified personnel.
- Perform monthly inspections or during scheduled maintenance visits to monitor brake pad clearance from the guide rail and brake pad surface.
- Clean brake components regularly to remove dirt, dust, and debris.
- Bi-annually, check all bolt connections between the caliper body and the car structure to ensure they meet manufacturer specifications.
- Bi-annually, inspect caliper assemblies for oil leaks around pistons and end caps. Seals have an undefined life expectancy - if leakage occurs, replace the seals.
- Bi-annually, inspect brake pads for any type of wear.
- Annually, verify equal setting for each brake pad on each side of the guide rail to ensure proper settings and clearances.
- Replace brake pads once they reach 1/8” thickness (pad material only). New brake pads vary in sizing/thickness depending on rail size. Sizing/thickness can range from 1/4” to 5/8” thick. Brake pads should be replaced when wear indicator indicates wear. If wear indicator is not available on that model, verification of the 1/8” thickness shall be followed.
- Typical brake pad life expectancy ranges between five (5) and fifteen (15) years depending on usage. Replace brake pads once they reach 1/8” thickness.
- Verify proper operation of the two retracting springs on each side of each brake pad at least once a month. Replace both springs if they do not operate correctly.
- Verify proper operation of both safety micro switches (one per brake pad) as per code requirements. Replace any faulty switches.
- Check for oil leakage around the piston area or back plate on each caliper side. Light oil residue around the wiper seal on each piston is normal. Replace seals if any other leakage occurs.
- Check for oil leakage around pressure fittings and bleeder valve to verify proper operation.

Power Unit – Maintenance

- **Maintenance tasks must be performed by qualified personnel only.**
- **In case of faults or damage, immediately switch off the hydraulic system.**
- **Document all maintenance activities in a maintenance log.**
- **Monthly inspections are recommended but not mandatory. Wipe down the unit to remove any oil residue.**
- **Bi-annually, check all electrical connections.**
- **Bi-annually, check for any leakage.**
- **Bi-annually, check oil levels and fitting connections.**
- **Annually, check full operation of the power unit.**
- **The power unit is a self-contained sealed unit. Do not attempt to repair it, as this will void warranties. Identify and rectify issues such as improper voltage, mechanical binding around pistons, debris, or rust. If necessary, install a new power unit.**
- **Check the power unit and associated fittings for any leakage and replace fittings as required.**
- **Verify proper operation of relays and replace defective ones.**
- **Monthly or during scheduled maintenance visits, verify proper operation of the accumulator unit. HydraSafe Brake recommends replacement of accumulators every three (3) to five (5) years for optimal performance.**
- **Check wiring for corrosion, loose connections, or hazards. Replace wiring harness if malfunctions are detected.**
- **Inspect UL approved electrical box/housing for any deterioration and replace as required.**

HydraSafe Brake recommends replacing brake pads, seals, oil, safety switches, springs, and the accumulator every ten (10) years to ensure maximum Unintended/Ascending operation or sooner depending on hoistway conditions and wear and tear. Monitor job site conditions monthly to determine component longevity.



Code Compliant Testing Procedures

8.6.4.19.11 Ascending Car Overspeed Protection and Unintended Car Movement Devices, and Emergency Brake:

(a) Examinations. All working parts of ascending car overspeed protection and unintended car movement devices shall be examined to determine that they are in satisfactory operating condition and that they conform to the applicable requirements of 2.19.1.2(a) and 2.19.2.2(a).

(b) Tests. Ascending car overspeed protection shall be subjected to tests with no load in the car at the slowest operating (inspection) speed in the up direction.

(c) Tests. Unintended car movement shall be subjected to tests with no load in the car at the slowest operating (inspection) speed in the up direction.



Parts List

HydraSafe Brake Easy Model	#001
Unmachined Foundry Caliper Body	#001-01
Machined Caliper Body	#001-02
Mounting Plate	#002
X” crosshead	#002-X
Brake Pad – Set of Two	#003
Brake Pad Return Spring Assembly	#003-01
Brake Pad Pin	#003-02
Brake Pad Plate	#003-03
Composite Pads	#003-04
Piston	#004
End Cap	#004-01
Seal Kit – seals for one unit (two required for full set)	#005
End Cap Seal	#005-EC
Piston Primary Seal	#005-PS
Piston Wiper Seal	#005-WS
Activation Sensor	#006
316SS 1/4" 0.065” Wall Tubing, 5 ft.	#007
Oil	#007-01
Hydraulic fluid, according to DIN 51 524 Parts 2 to 3; ISO VG 10 to 68, according to DIN ISO 3448 – viscosity range: Type H – 800 mm ² /s, Type HD – 4-300 mm ² /s, Type Z – 6 - 500 mm ² /s	
Fittings	#008
Positionable Male Elbow, ISO Parallel Thread	#008-01
1/4” Union Tee	#008-02
Bleeder Valve	#008-03
1/4” Port Connector	#008-04
Steel Rivet	#008-05



Female Branch Tree #008-06

QC Stem, 1/4" MNPT #008-07

QC Body, 1/4" FNPT #008-08

Male Adapter (ISO Parallel Thread) #008-09

Male Elbow #008-10

Parker Hose, 1/4" MNPT Ends, 12.5" #008-11

QC Stem, 1/4" FNPT #008-12

Street Elbow..... #008-13

Male Connector #008-14

ISO Parallel Thread Gasket #008-15

HydraSafe Brake Plus Model #009

Controller Interface Board #009-01

Car Top Control Board #009-02

Relay 24VAC #009-03

Relay 110VAC #009-04

Fuse Block #009-05

Fuse #009-06

Run Start Capacitor #009-07

Valve Coil #009-08

Accumulator #010

INKA Hydraulic Unit (HAWE) #011

Power Unit #012

Power Unit Box – 21L #012-01

Test Switch #012-02

Brake Return Proximity Switch #012-03

Brake Return Proximity Bracket #012-04

Bracket Set #012-05

Roller Guide Plate #013

X” crosshead #013-X



CERTIFICATE OF COMPLIANCE

issued by Liftinstituut B.V.

Certificate no. : NA23-0842-1004-045-01 Revision no.: -

Description of the product : Emergency brake as ASD and UCMP

Trademark : HydraSafe

Model / Type no. : HydraSafe Brake

Name and address of the manufacturer : HydraSafe Brake
4553 W. Lexington Street
Chicago IL 60624 USA

Name and address of the certificate holder : HydraSafe Brake
4553 W. Lexington Street
Chicago IL 60624 USA

Certificate issued on the basis of the following requirements : ASME A17.1-2019/CSA B44:19

Test laboratory / location : None

Date and number of the laboratory report : None

Date of verification of compliance : November 2023

Annexes with this certificate : Certificate of Compliance Report
no: NA23-0842-1004-045-01

Additional remarks : None

Conclusion : The Component as referred to in this certificate meets the requirements of the ASME A17.1-2019/CSA B44:19, considering any additional remarks mentioned above

Certification decision by

W.G. Kasteleijn
Product Manager Certification

Amsterdam
Date : November 17, 2023
Valid thru : November 17, 2026



Certificate of Compliance

Certificate: 80202021 **Master Contract:** 304470
Project: 80202021 **Date Issued:** 2024-09-24
Issued to: Hydrasafe Brake
 4553 West Lexington Street
 Chicago, Illinois 60624
 United States

Attention: Kevin Cunningham

The products listed below are eligible to bear the CSA Mark shown with adjacent indicators 'C' and 'US' for Canada and US or with adjacent indicator 'US' for US only or without either indicator for Canada only.



Issued by: Tai Pham
 Tai Pham

CSA B44.1/ASME A17.5

PRODUCTS

Class 2411 02 ELEVATOR EQUIPMENT - Enclosed Elevator – and Escalator Electrical Equipment
 Class 2411 82 ELEVATOR EQUIPMENT-Enclosed Elevator Electrical - Equipment-Certified to U.S. Standards

Elevator Emergency Hydraulic Brake Controller

Model(s)	Voltage (VAC)	Current (A max)	Frequency (Hz)	Phase	Coil Rating
HydraSafe Easy	110	6	60	1	24Vdc / 4A (Max)

Max Ambient 40°C

APPLICABLE REQUIREMENTS

CSA B44.1:19/ASME A17.5-2019 - Elevator and escalator electrical equipment



MAINTENANCE LOG

Traction & Hydraulic Maintenance Requirements

Month/Year: _____ Job Name: _____ Job Location: _____ Unit #: _____

HydraSafe® Brake recommends monthly maintenance but is not required and should be based on contractual visits or AHJ guidelines along with ASME code compliancy. HydraSafe® Brake recommends these maintenance procedures take place on your next scheduled visit in order to achieve optimum performance from our product lines.

Monthly Maintenance (Recommended but not required)	Twelve Times / Year											
Brake Unit	J	F	M	A	M	J	J	A	S	O	N	D
Check for any type of damage, oil around seals, or loose parts. A17.1.8.6.5.5												
Monitor brake pad clearance from guide rail and brake pad surface. A17.1.8.6.4.6.1(a)(b)												
Clean brake components to remove dirt, dust, and debris. A17.1.8.6.4.5.1												
Verify proper operation of the two retracting springs on each side of each brake pad. Replace both springs if they do not operate correctly. A17.1.8.6.4.6.1(d)												
Verify proper operation of both safety micro switches (one per pad) as per code requirements. Replace any faulty switches. A17.1.8.6.4.19.11 (a)												
Check for oil leakage around the piston or back plate on each caliper side. Light oil residue around the wiper seal on each piston is normal. Replace seals if any other leakage occurs. A17.1.8.6.5.5.1												
Check for oil leakage around pressure fittings and bleeder valve. A17.1.8.6.5.9												
Power Unit	J	F	M	A	M	J	J	A	S	O	N	D
Wipe down the unit to remove any oil residue. A17.1.8.6.5.1.1												
Check the power unit for leakage around the unit itself and its associated fittings. Replace any fittings as required. A17.1.8.6.5.5.1												
Verify proper operation of accumulator unit. HydraSafe Brake recommends replacement every 3 to 5 years for optimal longevity. A17.1.8.6.4.19.11 (a)												
Check all wiring for corrosion, loose connections, or any type of individual job hazards. If any malfunctions are detected a new wiring harness shall be installed. A17.1.8.6.4.20.10												
Inspect UL approved electrical box/housing for any deterioration and if any is detected replace as required. NFPA 70-NEC 620												
Verify all relays are operating to manufacture specifications. NFPA 70-NEC 620												
Semi-Annual Maintenance	Two Times / Year											
Brake Unit	J	F	M	A	M	J	J	A	S	O	N	D
Check all bolt connections on the caliper body to the car structure and verify they are within manufactures specifications. A17.1.2.8.6												
Inspect the caliper assemblies for any oil leaks around the pistons and end caps. If leakage occurs, replace the seals. A17.1.8.6.5.5.1												
Inspect the brake pads for any type of wear. A17.1.8.6.4.6.1(a)(b)												
Power Unit	J	F	M	A	M	J	J	A	S	O	N	D
Check all electrical connections. NFPA 70-NEC 620												
Check oil levels. A17.1.8.6.5.5.1												
Check fitting connections. A17.1.8.6.5.5.1												
Annual Maintenance	One Time / Year											
Test for proper operation as per A17.1 8.6.4.19.11 for Code compliancy.												
Verify equal setting for each brake pad on each side of guide rail to ensure proper settings and clearances. A17.1.8.6.4.6.1(a)(b)												